

TECHNICAL DATA

TANDEM ROLLERS

BW 161 AD - 50, BW 202 AD - 50, BW 206 AD-50

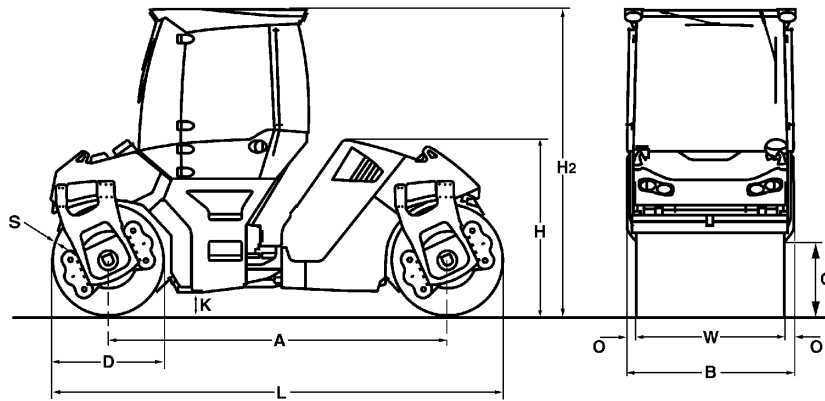



Dimensions in mm

	A	B	C	D	H	H2	K	L	O	S	W
BW 161 AD - 50	3620	1836	670	1220	2315	3050	250	4840	78	17	1680
BW 202 AD - 50	3620	2291	670	1220	2315	3050	250	4840	78	19	2135
BW 206 AD-50	3900	2313	760	1400	2364	3093	250	5300	89	19	2135

Shipping dimensions in m3

BW 161 AD - 50
BW 202 AD - 50
BW 206 AD-50

without ROPS

20,572
 25,670
 28,980

with ROPS

27,103
 33,820
 37,917

Machine type	Compaction output (m3/h) at recommended soil layer thicknesses		
	Gravel, sand	Mixed soil	Silt, clay
BW 161 AD - 50	150-320	140-260	100-220
BW 202 AD - 50	280-550	200-400	150-250
BW 206 AD-50	280-550	200-400	150-250

Machine type	Compaction output (t/h) at different asphalt layer thicknesses		
	2-4 cm	6-8 cm	10-14 cm
BW 161 AD - 50	50-100	100-200	150-230
BW 202 AD - 50	80-160	130-270	200-340
BW 206 AD-50	90-180	150-300	250-500

Technical Data**BOMAG
BW 161 AD - 50****BOMAG
BW 202 AD - 50****BOMAG
BW 206 AD-50****Weights**

Operating weight CECE w. cab.	kg	10.000	12.300	14.100
Axle load, front CECE	kg	5.100	6.350	6.950
Axle load, rear CECE	kg	4.900	5.950	7.150
Static linear load, front CECE	kg/cm	30,4	29,7	32,6
Static linear load, rear CECE	kg/cm	29,2	27,9	33,5
Grossweight	kg	10.500	13.000	16.000

Dimensions

Track radius, inner	mm	4.900	4.673	5.117
---------------------------	----	-------	-------	-------

Driving Characteristics

Max. travel speed	km/h	0- 11,5	0- 12,0	0- 12,0
Max. gradeability without/with vibr. ...	%	35/30	35/30	35/30

Drive

Engine manufacturer		Deutz	Deutz	Deutz
Type		BF4M 2012 C	BF4M 2012 C	BF4M 2012 C
Emission stage		Stage II / TIER2	Stage II / TIER2	Stage II / TIER2
Cooling		Liquid	Liquid	Liquid
Number of cylinders		4	4	4
Performance ISO 14396	kW	103,0	103,0	103,0
Performance SAE J 1995	hp	138,0	138,0	138,0
Speed	min-1	2.500	2.500	2.500
Electric equipment	V	12	12	12

Brakes

Service brake		hydrost.	hydrost.	hydrost.
Parking brake		multi disc	multi disc	multi disc

Steering

Steering system		oscil.artic.	oscil.artic.	oscil.artic.
-----------------------	--	--------------	--------------	--------------

Exciter system

Vibrating drum		front + rear	front + rear	front + rear
Autom. vibr. shut off		standard	standard	standard
Frequency	Hz	40/55	40/55	40/55
Amplitude	mm	0,87/0,44	0,84/0,31	0,92/0,42
Centrifugal force	kN	95/90	126/88	129/113
Centrifugal force	t	9,7/9,2	12,8/9,0	13,1/11,5

Capacities

Fuel	l	145,0	145,0	165,0
Water	l	750,0	750,0	970,0

Technical modifications reserved. Machines may be shown with options.

Standard Equipment

- 2 amplitudes / 2 frequencies
- Autom. vibration operation
- Individual vibration control
- Driver's seat, slewable (-20/+70°)
- laterally slidable with steering wheel
- V-belt protection
- Pressure sprinkling system with 2 pumps
- Back-up alarm
- Battery disconnect switch
- Folding scrapers

Optional Equipment

- ROPS cabin with seat belts
+ heating, Ventilation
+ 4 Working head lights
- ROPS cabin with air conditioning
- Rotary beacon
- 2 LED-lights for cabin roof (flatbeam)
- ROPS/FOPS
- Asphalt temperature display
- Crab walk
- BOMAG TELEMATIC START
- Compartments for documents and tools
- Outside mirrors
- Working lights
- Lights with german regulations
- Frequency
67Hz(BW161),70Hz(BW202/206)
- BOMAP compaction navigation with
GPS
- ECONOMIZER
- Edge cutter

