

TECHNICAL DATA

TANDEM ROLLERS

BW 135 AD-5, BW 138 AD-5

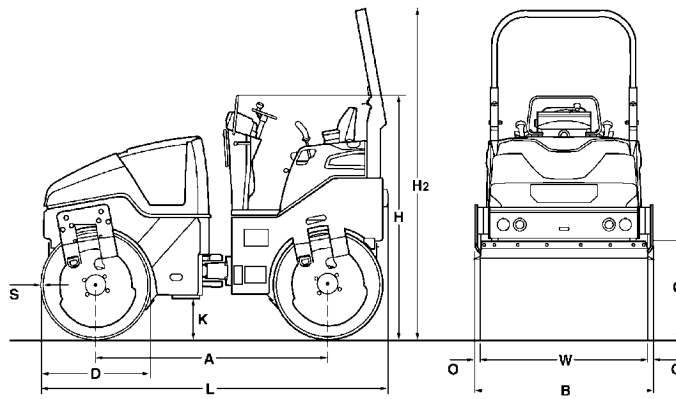



Dimensions in mm

	A	B	C	D	H	H2	K	L	O	S	W
BW 135 AD-5	1900	1390	700	900	1895	2703	340	2840	44	16	1300
BW 138 AD-5	1900	1468	700	900	1895	2703	340	2840	44	18	1380

Shipping dimensions in m3

BW 135 AD-5
BW 138 AD-5

without ROPS

7,481
 7,900

with ROPS

10,670
 11,269

Machine type	Compaction output (m3/h) at recommended soil layer thicknesses		
	Gravel, sand	Mixed soil	Silt, clay
BW 135 AD-5	90-180	70-140	40-80
BW 138 AD-5	100-200	80-160	40-80

Machine type	Compaction output (t/h) at different asphalt layer thicknesses		
	2-4 cm	6-8 cm	10-14 cm
BW 135 AD-5	30-55	50-85	75-130
BW 138 AD-5	30-55	50-90	75-135

Technical Data**BOMAG
BW 135 AD-5****BOMAG
BW 138 AD-5****Weights**

Operating weight w. ROPS CECE	kg	4.000	4.450
Average static linear load CECE	kg/cm	15,4	16,1
Grossweight	kg	5.500	5.500

Dimensions

Working width	mm	1.300	1.380
Track radius, inner	mm	2.665	2.616

Driving Characteristics

Speed	km/h	0- 10,0	0- 10,0
Working speed with vibration	km/h	0- 10,0	0- 10,0
Max. gradeability without/with vibr.	%	40/30	40/30

Drive

Engine manufacturer		Kubota	Kubota
Type		V 2203	V 2203
Emission stage		Stage IIIa / TIER4i	Stage IIIa / TIER4i
Cooling		water	water
Number of cylinders		4	4
Performance ISO 14396	kW	33,3	33,3
Performance SAE J 1995	hp	44,7	44,7
Speed	min-1		2.600
Speed adjustment 1	min-1	2.140	2.770
Speed adjustment 2	min-1	2.770	2.140
Electric equipment	V	12	12
Driven drum		front + rear	front + rear

Brakes

Service brake		hydrost.	hydrost.
Parking brake		hydromec.	hydromec.

Steering

Steering system		oscil.artic.	oscil.artic.
Steering method		hydrost.	hydrost.
Steering / oscillating angle +/-	grad	32/10	32/10
Crab walk	mm	0- 50	0- 50

Exciter system

Vibrating drum		front + rear	front + rear
Drive system		hydrost.	hydrost.
Frequency	Hz	50/56	50/56
Amplitude	mm	0,50	0,50
Centrifugal force	kN	39/48	45/57

Sprinkler System

Type of sprinkling		pressure	pressure
--------------------------	--	----------	----------

Capacities

Fuel	l	55,0	55,0
Water	l	310,0	310,0

Technical modifications reserved. Machines may be shown with options.

Standard Equipment

- Hydrostatic travel and vibration drive
- 2 scrapers per drum, spring loaded and tiltable
- Pressure sprinkler system with interval switch
- Multi function travel lever
- Multi-function display incl. operating hour meter
- Water level
- Electronic fuel gauge
- Emergency STOP
- Individual control, vibration
- Intelligent Vibration Control (IVC)
- Integrated storage compartment
- Sliding seat incl. double travel lever
- Seat contact switch
- 12V socket
- Working lights front and rear
- Vandalism protection
- Lockable engine hood made of composite material
- Lashing eyes, galvanized
- Single point lifting device
- Back-up alarm

Optional Equipment

- *Foldable ROPS incl. seat belt
- Sun roof, rigid
- Sun roof, foldable with ROPS
- Weather protection for sun roof
- Weather protection cabin
- Seat heating
- ECONOMIZER with asphalt temperature display
- Temperature display
- BOMAG TELEMATIC
- Indicator and hazard lights
- Rotary beacon
- Optional lighting on ROPS
- Lighting for drum edge
- Battery disconnect switch
- Environmentally compliant hydraulic oil
- Theft protection
- Edge cutter-right/left
- Gravel scatterer
- Hydraulically adjustable crabwalk (50mm)
- Pointer
- Special painting
- Backup warning buzzer with broadband technology
- Flow divider
- 2. Amplitude:0,2mm
- ECOSTOP
- Outside mirrors
- Tablet holder set

* Standard delivery with CE conformity
(valid within European Union)

